

WPCI

Intermodal Transport

Hamburg, Jan Egbertsen, 18-11-2009

Content

- Future development
- Role Port Authority
- WP 1 questionair port authority and intermodal strategy
- WP 2 cases intermodal projects in seaports
- WP 3 discussion platform internet
- WP 4 model port intermodal strategy

Future development

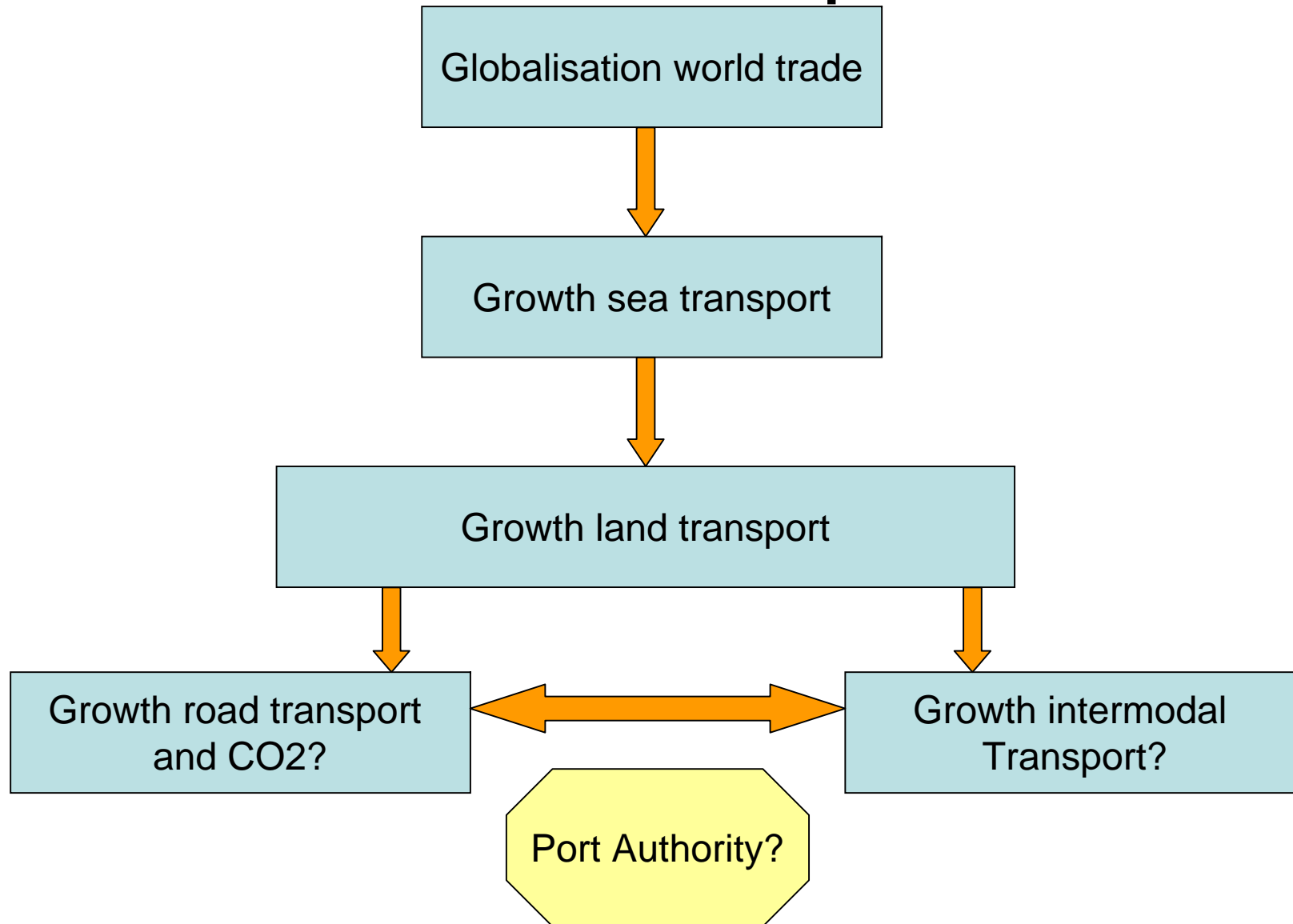

Intermodal transport and Port Authority

- Port Authorities do not handle cargo or decide on modality
- Port Authorities can influence:
 - Feasibility studies
 - Subsidies
 - Pilot projects
 - Promotion of intermodal transport
 - Lease contracts
 - Intermodal infrastructure in port area and lobby national infrastructure
 - What else???
- Dry / liquid bulk => providing the right infrastructure
- Containers / general cargo => providing the right infrastructure and intermodal development
- In close cooperation with market (terminal operators, shippers, industry , logistic service providers)

WP 1: Port strategy and intermodal transport (questionair) (1)

- Cargo flow sea side (tons, present /2020)
- Present modal shift (% rail, truck, inland waterways, pipeline)
- Long term targets modal shift (2020, %)
- Intermodal vision and strategy?
- Financial funds intermodal development?

WP 1: Port strategy and intermodal transport (questionair) (2)

- Projects to improve intermodal transport?
- Organization (special department or employees for intermodal transport)
- Possible role of a port authority to improve intermodal transport?

WP 2, Case descriptions

- Cases development intermodal transport seaports.
- Critical success factors
- Lessons learned
- Role of Port Authority
- Target and results of project
- Partners involved
- Financing of project
- Who to contact for more information

WP 3: Open crowd innovation / open source innovation

- Ports are working on intermodal projects.
- How can we learn from each other?
- Open crowd innovation or open source innovation.
- Discussion group <http://www.linkedin.com> port and intermodal development. Please join us in the discussion.

Role of port authorities in intermodal transport?"

- Important, greater role, independent coordinator different parties, crisis give new chances
- Pricing policy, but competition
- USA: rules / bye-laws, Emission Control Areas in sensitive locations, facilitate localised clean energy production, cargo equipment movers to burn bio-fuel, strict regimes all vehicles entering port area to minimise 'bad' emissions
- Bring about the (im)possibilities of multimodality to all companies / relations using the port area.
- Facilitating 'open source' terminal facilities.
- Intermodal can influence quick decision new infrastructure

WP 4: Model Port Intermodal Strategy

- Based on results WP 1, 2, 3, lessons learned and best practices
- Model that Port Authorities can use to develop their own intermodal strategy.
- Vision and intermodal targets (long term and coming year).
- Long term intermodal strategy
- Action program for coming year.
- Finance and organization.
- Statistics (information about present modal split)

Intermodal transport and innovation

Role port authority?

A quick overview

Betuweroute

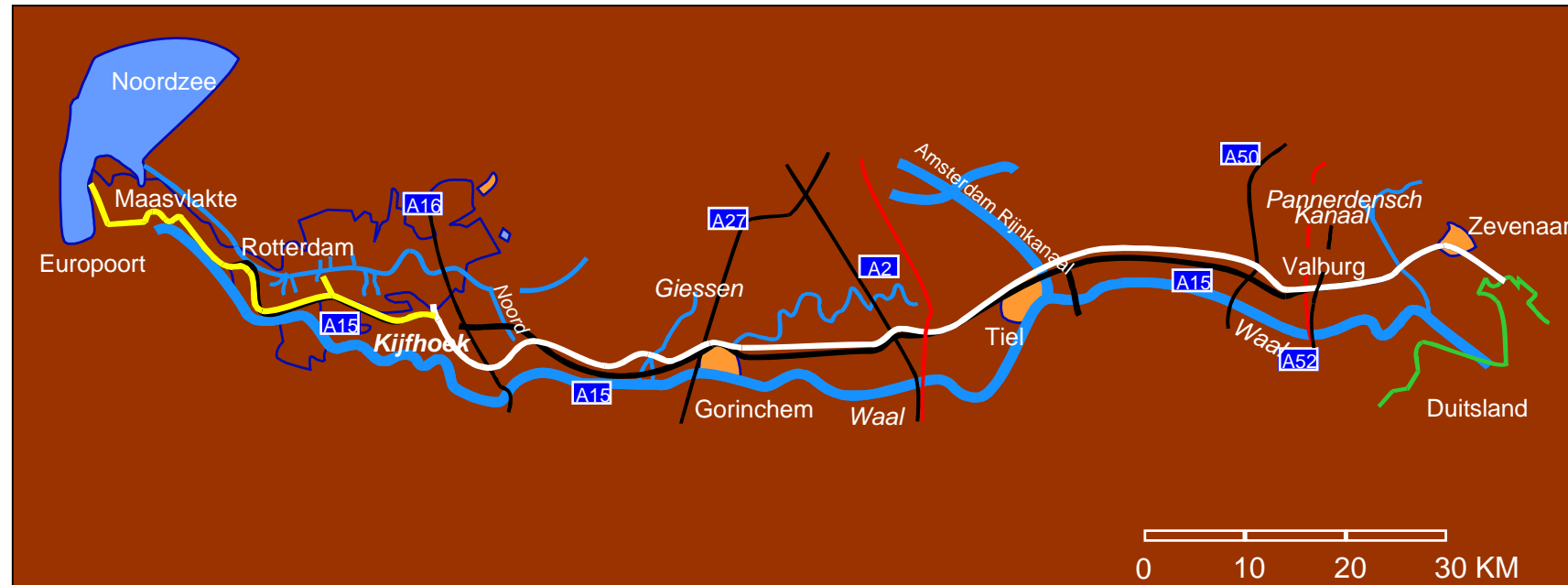

- Keyrail commercial exploitation of the Betuweroute
 - Maintenance, Capacity management and Traffic control
- 50% Prorail, 35% Port of Rotterdam, 15% Port of Amsterdam



AMS Barge



Super fast ferry

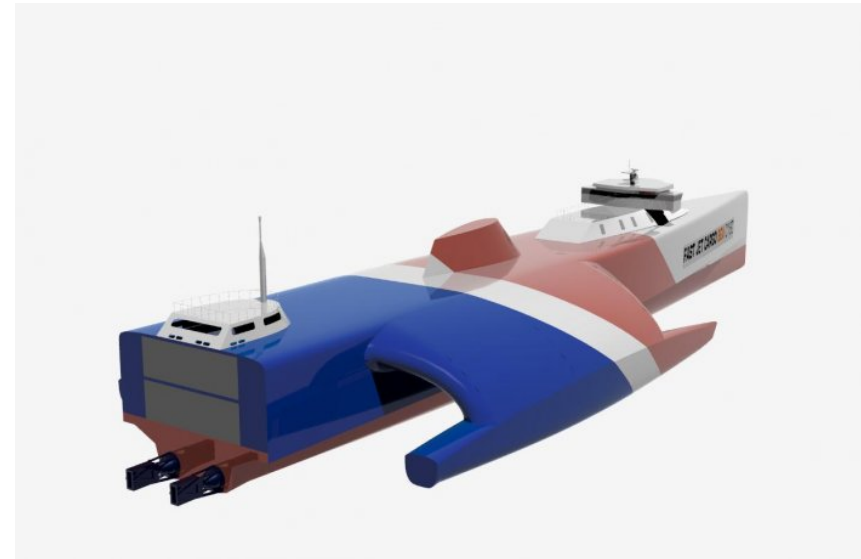

- 35 Knots (65 km/h versus 70 by road)
- Punctuality, reliability and safety
- Between France (Bologne sur Mer) and England (Dover)
- www.bgv-international.com

All Weather Terminal



- up to 7500 tons under all weather conditions (indoors, short sea, rail and barge)
- 3 covered berth (80 meters and 100 meters)
- 3 overhead cranes are used, lifting capacity 40 tons each

Portbase / ICT / RFID

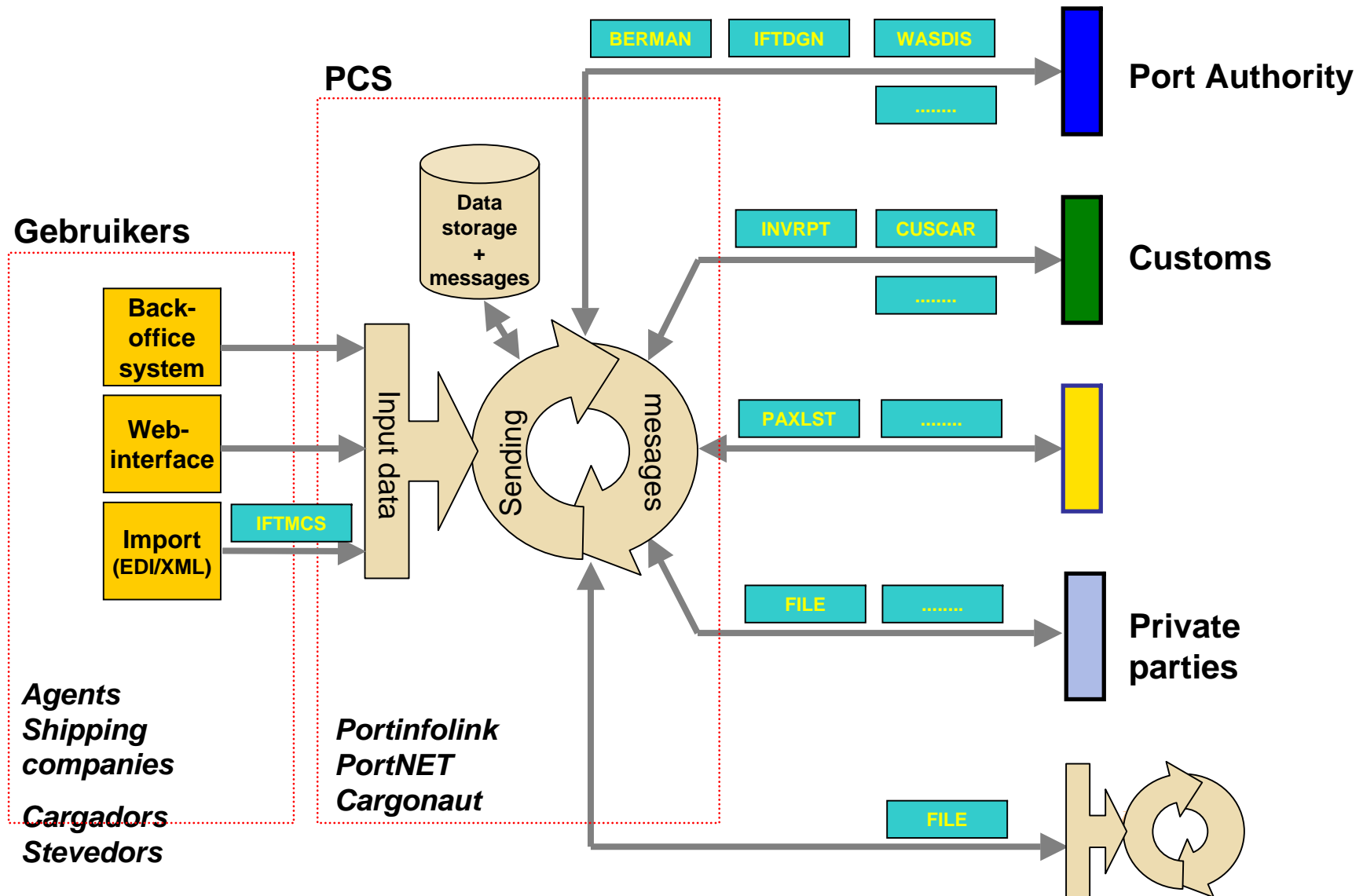

Organizational innovation

- Organize a regional Logistics Platform (co-ordination cargo owners, industries and logistic service providers)
- Integrated door – to - door intermodal concepts
- Independent integrated intermodal booking agency

Lessons learned

- Intermodal accessibility is of strategic importance for a port
- Focus from just the sea side also to the hinterlandside
- But Port Authority does not handle cargo, operates terminals or ships or trains!
- Projects are PPS, need involvement of industry and logistic service providers